

# 172×150×51mm (H.T.R.) 環境溫度100°C專用

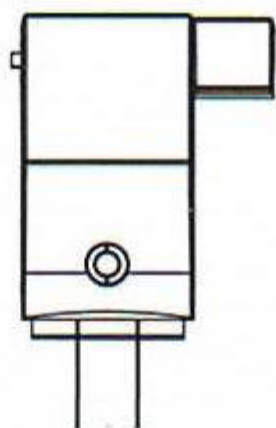

UNITS=mm

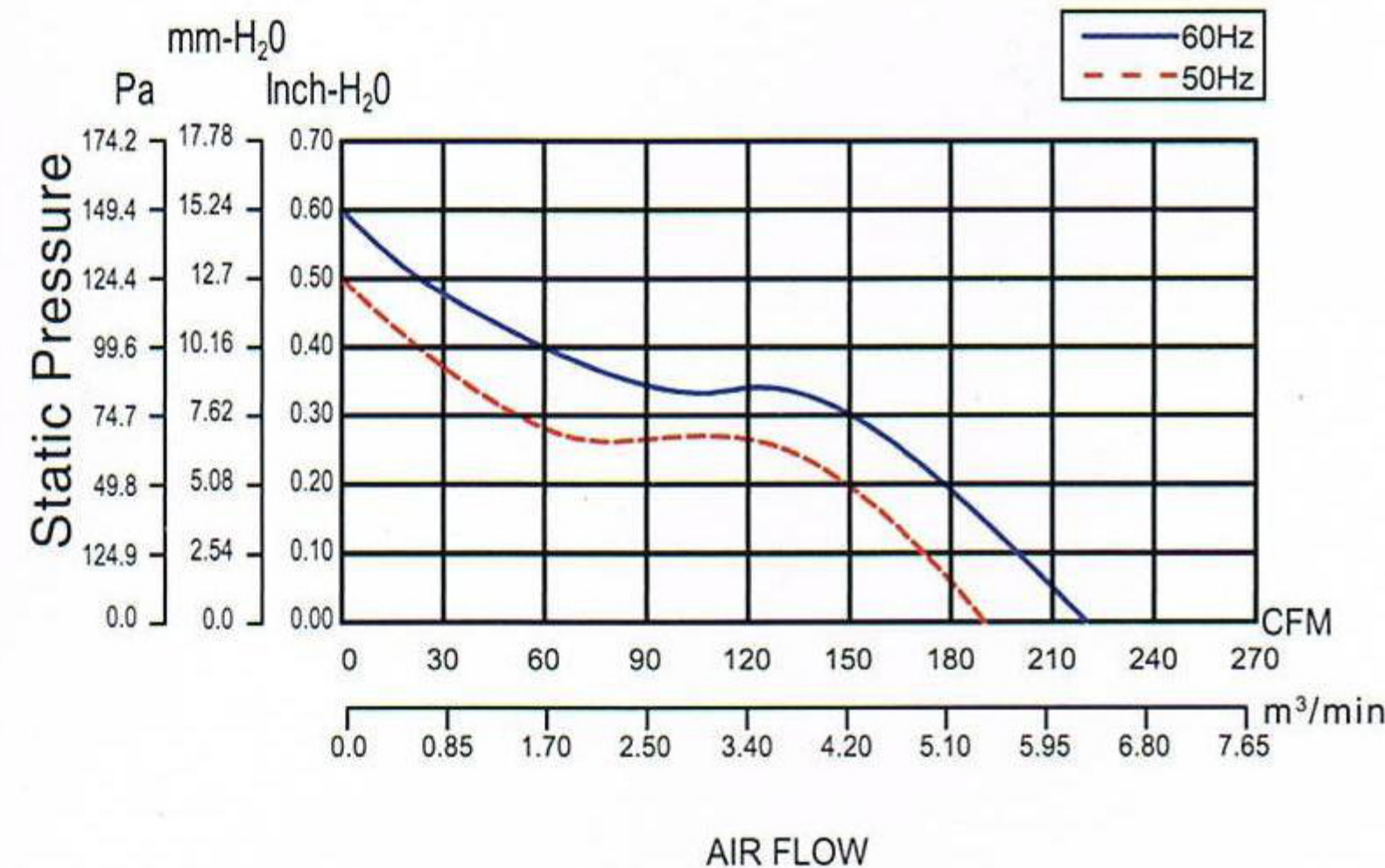
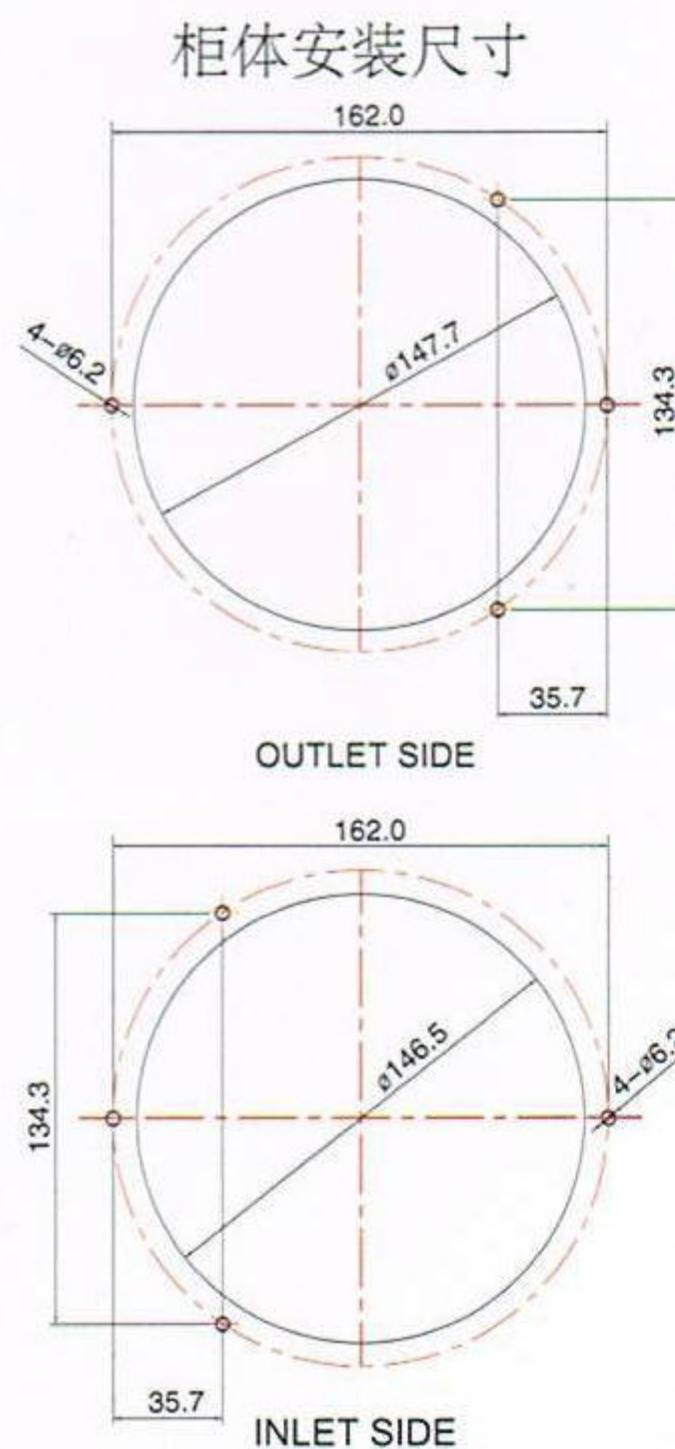
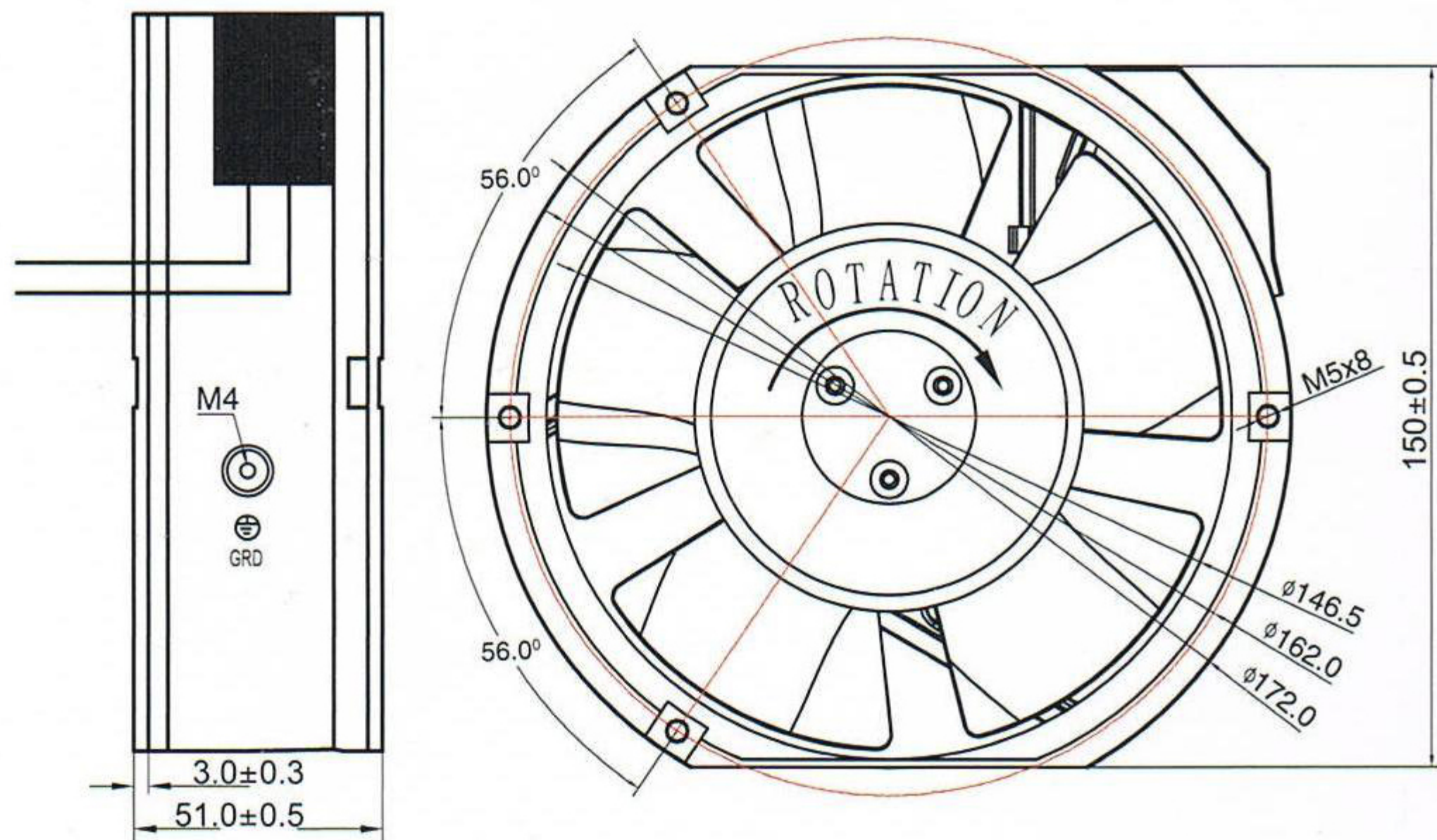

**H.T.R.100°C (SGS Approval)**  
 (F Class Enamelled Wire Inside)  
 Test Report No.:SHRL80027-2/2008

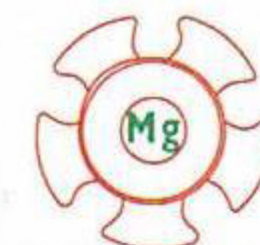

Model (型號)	Part No. Terminal Leadwire	Bearing System (培林)	Rated Voltage(v) (電壓)	Freq (Hz) (頻率)	Current (A) (電流)	Input Power(w) (功率)	Speed (rpm) (轉速)	Air Flow (CFM) (風量)	Static Pressure (inch-H <sub>2</sub> O) (靜壓)	Noise Leve(dB-A) (噪音值)	Weight (g) (重量)
KA1725HA1/H.T.R.100(IP55)	1725HA1BML	Ball	110/120	50/60	0.43/0.36	33/31	2700/3100	190/220	0.50/0.60	60/62	805
KA1725HA2/H.T.R.100(IP55)	1725HA2BML	Ball	220/240	50/60	0.18/0.15	32/30	2700/3100	190/220	0.50/0.60	60/62	805
KA1725HA3/H.T.R.100(IP55)	1725HA3BML	Ball	380/400	50/60	0.09/0.11	33/31	2700/3100	190/220	0.50/0.60	60/62	805

最新數據訊息，請予網上查詢！ Please check our website in case any update data.

注：其他轉速可特殊定制。